

MB20J/MB26J

MAST BOOM LIFTS



- Versatile electric mast booms
- Ultra-narrow for use in confined spaces
- Superb working envelope including "up & over" capabilities
- Simple to operate and maintain
- Ideal for retail and warehouse applications

 **snorkel**
www.snorkellifts.com

MAST BOOM LIFTS

MB20J/MB26J

DIMENSIONS	MB20J	MB26J
Max. working height	8.1m	9.8m
Max. platform height	6.1m	7.8m
Max. working outreach	2.6m	3.0m
Platform size	0.78m x 0.73m	0.78m x 0.73m
Overall width (A)	0.81m	1.0m
Stowed length (C)	2.41m	2.8m
Stowed height (B)	1.98m	1.98m
Ground clearance	100mm	100mm

PERFORMANCE		
Platform capacity (SWL)	215kg	215kg
Max. drive height	6.1m	7.8m
Max. wind speed	12.5m/s	12.5m/s
Max. drive speed (stowed)	3.2km/h	3.2km/h
Max. drive speed (elevated)	0.48km/h	0.48km/h
Jib length	1.02m	1.4m
Jib arc	130°	130°
Mast rotation (non-continuous)	360°	360°
Raise/lower time	54/26sec	56/27sec
Gradeability	25%	25%
Inside turning radius	0.3m	0.3m
Outside turning radius	1.83m	2.1m
Tyres	343-285 non-marking rubber	
Controls	proportional controls	
Drive system	electro/hydraulic	

POWER	
Power source	4 x 6V x 375Ah batteries

WEIGHT		
Weight	2,590kg	2,660kg

WORKING ENVELOPE

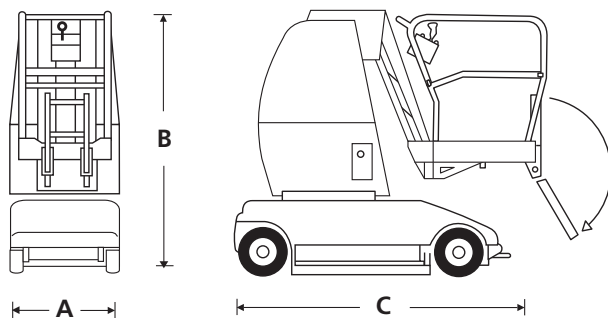
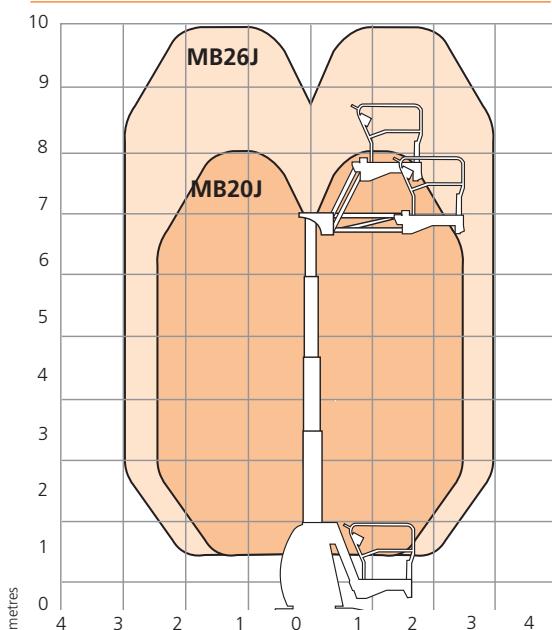

STANDARD FEATURES

- Ultra-tight inside turning radius
- Proportional controls
- Tilt alarm
- Non-marking tyres
- Hydraulic pothole protection system
- 2 persons + equipment capacity indoor
- 1 person + equipment capacity outdoor
- Self-seeking automatic battery charger
- Automatic battery fill
- Power line to platform
- Hour meter & on-board diagnostics display
- 2 year parts & labour, 5 year structural warranty
- CE approved

OPTIONS

- Special paint colours
- Flashing amber light
- Environmental (green) oil



Vigo Centre, Birtley Road,
Washington, Tyne & Wear,
NE38 9DA, U.K.

t: +44 (0) 845 1550 057

e: sales@snorkellifts.com

www.snorkellifts.com